



3WHML, 3WHMXL

High-efficiency ECM circulators

1 x 230 V

50/60 Hz



1. General information

Introduction

This data booklet applies to WASSERAMNN WHML,WHMXL pump range.

- WHML xx-105/125/140 AUTO
- WHML xx-105/125/140 PWM
- WHMXL xx-110/120/160/180 AUTO
- WHMXL xx-110/120/160/180 PWM

System applications

WHML,WHMXL are designed for circulating liquids in heating systems.

The pumps are suitable for the following systems:

- systems with constant or variable flows where it is desirable to optimise the pump duty point.
- installation in existing systems where the differential pressure of the pump is too high during periods of reduced flow demand.
- installation in new systems for automatic adjustment of the performance to flow demands without the use of bypass valves or similar expensive components.

Examples of systems

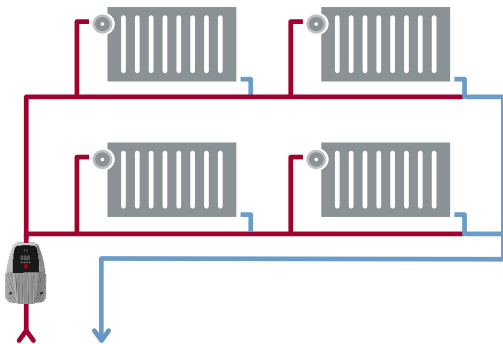

One-pipe heating system

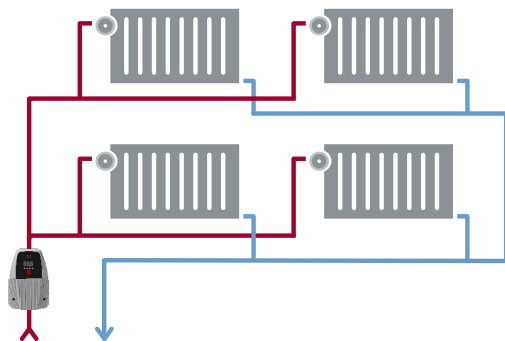

Two-pipe heating system

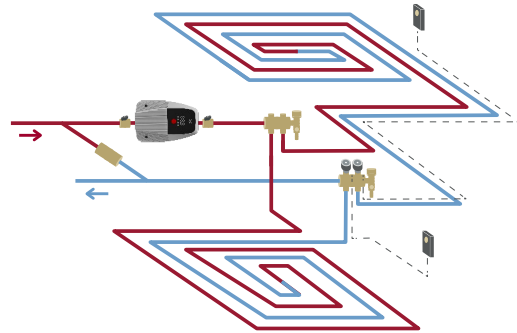

Underfloor heating system

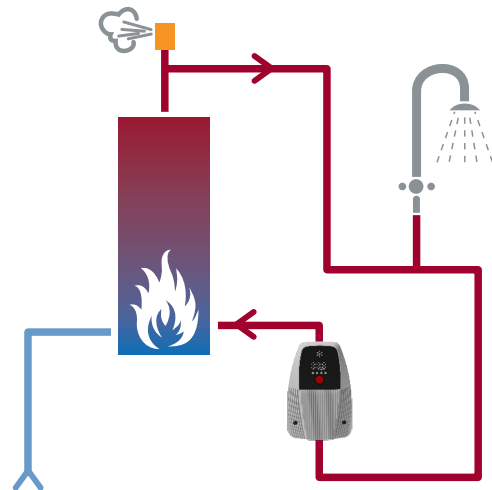

Domestic hot-water recirculation system

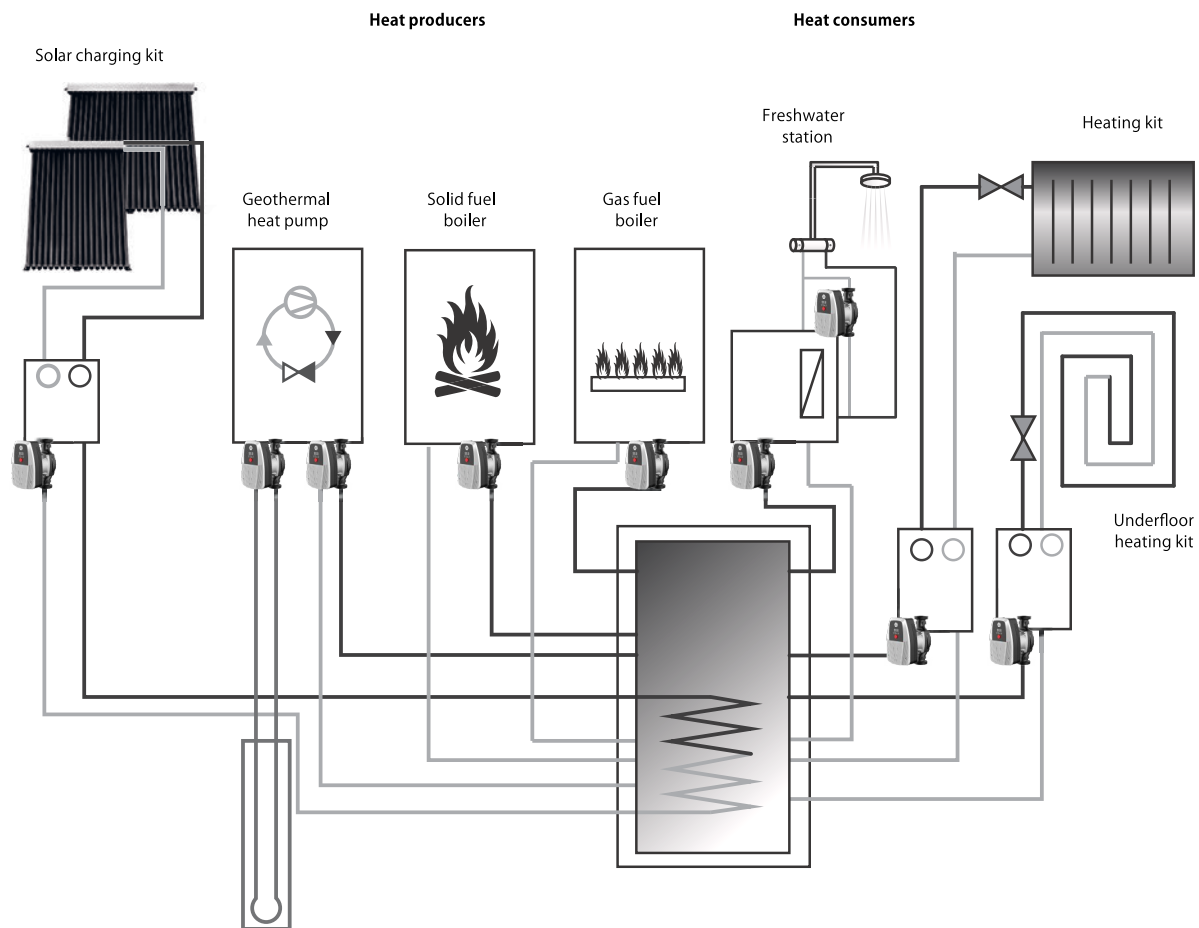

Fig. Complete domestic heating system combined with renewable energy sources

On the generation side, most pumps are externally controlled via control signal (PWM) by the appliance control. The pumps on the distribution side are often stand-alone pumps and mainly internally controlled (AUTO version). The pumps in circuits with variable flow are differential-pressure controlled either as constant pressure (CP) or proportional pressure (PP) control. With AUTOADAPT, the control curve is automatically adapted to the actual requirements of the respective application.

For domestic hot water systems, we must offer pumps with stainless-steel or plastic housings that have the necessary drinking water approvals like UBA, KTW, DVGW, ACS, KIWA or WRAS.

For solar thermal systems, SOLAR WHML, SOLAR WHMXL pumps are available, which are suitable for solar media containing glycol up to 110 C (peak). They use the PWM-C signal profile, which is inverse of the PWM-A signal profile. The PWM-C signal profile stops the pump and avoids that the pump runs and overheats or unloads the storage tank, if the signal is missing.

Features

The WHML, WHMXL range offers a number of important features and benefits for the customer:

- Suitable for heating, solar-thermal systems, geothermal heat pumps and cooling.
- Internally or externally speed-controlled, high-efficiency pumps with electronically commutated motor (ECM) with permanent-magnet rotor and frequency converter.
- Improved motor technology and hydraulics for high pump efficiency.
- Meets all Ecodesign requirements of the ErP regulation EU/622/2012.
- Functional design concentrating on the essentials, fitting in the smallest space.
- Easy operation and convenient setting via external control signals or button.
- Electronics separated from the motor for operation in condensing environment.
- Motor protected against condensed water by means of drain holes and double-coated wiring.
- Fits into the confined space inside boilers and heat pumps.
- Electrical compatibility with existing PWM controllers.
- Low ambient temperature constraints (EN 60335).
- Electrocoated cast-iron housing for the prevention of inside and outside corrosion.
- Low flow noise.
- High starting torque for reliable starting.
- Suitable for cold antifreeze media containing glycol or ethanol.
- Standard delivery with plug for easy electrical connection and quick and safe installation.

Benefits Features

- Use up to 80% less electrical power than conventional constant-speed pumps.
- Use up to 60% less electrical power than conventional speed-controlled pumps.

ErP, Ecodesign regulation in brief

The EU has addressed the climate challenge in a EuP/ErP directive: Since August 2015, all stand-alone pumps as well as pumps integrated in boiler systems, solar systems and heat pump systems must fulfil Ecodesign requirements, defined in regulation 641/2009/EC on glandless pumps, which was amended by 622/2012/EC. The regulation has set radically new standards for energy efficiency.

The essentials Features

- Glandless pumps integrated in products must have an energy efficiency index (EEI) of not more than 0.23. The benchmark level is 0.20.
- Stand-alone pumps are measured according to EN 16297-2.
- Integrated pumps are measured according to EN 16297-3, due to their various functions integrated in many customised hydraulic solutions on the market.
- All pumps integrated in products which generate and/or transfer heat and all types of media are included. This means that not only heating systems, but also solar-thermal and heat pump systems are affected by the Ecodesign regulation.
- Non-compliant spare pumps for integrated pumps sold before August 2015 are allowed until January 1st, 2022.
- Pumps designed for recirculation of drinking water are out of the scope of this regulation.
- Pumps designed for recirculation of drinking water are out of the scope of this regulation.
- Conformity with EU regulations is governed through mandatory CE marking.

2. Product range

3WHML,WHMXL

1 × 230-240V,50/60 Hz



No.	Model	P1 max [W]	Port to port space [mm]	Body material	Connection	Control
1	WHML25-105	140	130/180	Cast iron	G11/2	AUTO/PWM
2	WHML25-105P	140	130	Plastic	G11/2	AUTO/PWM
3	WHML25-105N	140	130/180	Stainless steel	G11/2	AUTO/PWM
4	WHML32-105	140	180	Cast iron	G2	AUTO/PWM
5	WHML32-105N	140	180	Stainless steel	G2	AUTO/PWM
6	WHML25-125	180	130/180	Cast iron	G11/2	AUTO/PWM
7	WHML25-125P	180	130	Plastic	G11/2	AUTO/PWM
8	WHML25-125N	180	130/180	Stainless steel	G11/2	AUTO/PWM
9	WHML32-125	180	180	Cast iron	G2	AUTO/PWM
10	WHML32-125N	180	180	Stainless steel	G2	AUTO/PWM
11	WHML25-140	190	130/180	Cast iron	G11/2	AUTO/PWM
12	WHML25-140P	190	130	Plastic	G11/2	AUTO/PWM
13	WHML25-140N	190	130/180	Stainless steel	G11/2	AUTO/PWM
14	WHML32-140	190	180	Cast iron	G2	AUTO/PWM
15	WHML32-140N	190	180	Stainless steel	G2	AUTO/PWM
16	WHMXL25-110	250	180	Cast iron	G11/2	AUTO/PWM
17	WHMXL25-110N	250	180	Stainless steel	G11/2	AUTO/PWM
18	WHMXL32-110	250	180	Cast iron	G2	AUTO/PWM
19	WHMXL32-110N	250	180	Stainless steel	G2	AUTO/PWM
20	WHMXL25-160	250	180	Cast iron	G11/2	AUTO/PWM
21	WHMXL25-160N	250	180	Stainless steel	G11/2	AUTO/PWM
22	WHMXL32-160	250	180	Cast iron	G2	AUTO/PWM
23	WHMXL32-160N	250	180	Stainless steel	G2	AUTO/PWM
24	WHMXL25-120	350	180	Cast iron	G11/2	AUTO/PWM
25	WHMXL25-120N	350	180	Stainless steel	G11/2	AUTO/PWM
26	WHMXL32-120	350	180	Cast iron	G2	AUTO/PWM
27	WHMXL32-120N	350	180	Stainless steel	G2	AUTO/PWM
28	WHMXL25-180	350	180	Cast iron	G11/2	AUTO/PWM
29	WHMXL25-180N	350	180	Stainless steel	G11/2	AUTO/PWM
30	WHMXL32-180	350	180	Cast iron	G2	AUTO/PWM
31	WHMXL32-180N	350	180	Stainless steel	G2	AUTO/PWM



No.	Model	P1 max [W]	Port to port space [mm]	Body material	Connection	Control
1	WHMXL32-80F	250	220	Cast iron	DN32	AUTO/PWM
2	WHMXL32-100F	350	220	Cast iron	DN32	AUTO/PWM
3	WHMXL32-120F	400	220	Cast iron	DN32	AUTO/PWM
4	WHMXL40-80F	250	250	Cast iron	DN40	AUTO/PWM
5	WHMXL40-100F	350	250	Cast iron	DN40	AUTO/PWM
6	WHMXL40-120F	400	250	Cast iron	DN40	AUTO/PWM

3. Identification

Type key

Example: _____ WHM XL 32 -120 F 220 AUTO BMC

Type

WHM = Standard

SOLAR WHM = For solar systems

Power variant

L = 140 ~ 190W

XL = 250 ~ 400W

Nominal diameter

25 R 1" / G 1 1/2"

32 R 1 1/4" / G 2"

Nominal head

105 10.5m

125 12.5m

140 14.0m

... ..

= Threaded ports

F = Flanged ports

Pump housing, port-to-port length

130 Cast iron , 130 mm

180 Cast iron , 180 mm

220 Cast iron , 220 mm

250 Cast iron , 250 mm

N 180 Stainless steel , 180 mm

P 130 Plastic , 130mm

B 130 Brass , 130mm

Control variant

AUTO Internally controlled

PWM Externally controlled via PWM

Encapsulated motor with AL. case

BMC BMC motor

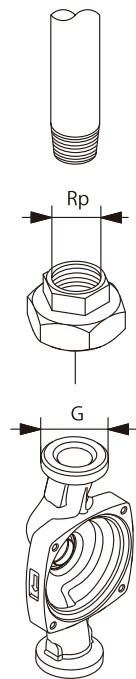

G-threads and R-threads

Nameplate

3WHML,WHMXL

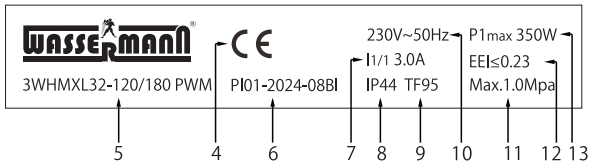
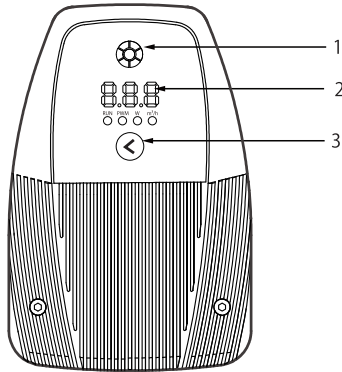

Pos	Description
1	Running light
2	Control mode LED
3	Control mode setting button
4	CE mark
5	Product type
6	Serial number
7	Maximum current [A]
8	Enclosure class
9	Temperature class
10	Voltage and frequency [V , Hz]
11	Maximum system pressure [Mpa]
12	Energy index
13	Input power [W]

4. Control modes and settings

Pump control in heating systems

The heating required in a building varies greatly during the day due to changing outdoor temperatures, solar radiation and heat emanating from people, electric appliances, and others. In addition, the need for heating may vary from one section of the building to another and the thermostatic valves of some radiators may have been turned down by the users. An uncontrolled pump will produce a too high differential pressure when the heat demand and flow are low.

Possible consequences:

- too high energy consumption
- irregular control of the system
- noise in thermostatic radiator valves and similar fittings

WASSERMANN WHML AUTO, WHMXL AUTO pumps automatically control the differential pressure by adjusting the performance to the actual heat demand, without the use of external components.

Control mode explanation

WHML PWM, WHMXL PWM - externally controlled by a control signal from the system controller

All WHML, WHMXL pumps are available with external digital PWM control signal.

PWM A profile (heating) (externally controlled)



The pump runs on constant-speed curves depending on the current PWM value (regarding VDMA 24244).

The speed decreases when the PWM value increases. If PWM equals 0, the pump runs at maximum speed.

PWM C profile (solar) (externally controlled)





The pump runs on constant-speed curves depending on the current PWM value.

The speed increases when the PWM value increases. If PWM equals 0, the pump stops.

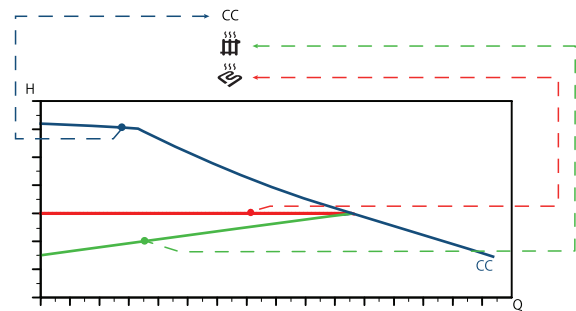
Quick overview of control modes



Pump setting in relation to performance

Setting	Pump curve	Function
	Proportional-pressure curve	The duty point of the pump will move up or down on a proportional-pressure curve, depending on the heat demand in the system. The head (pressure) is reduced at falling heat demand and increased at rising heat demand.
	Constant-pressure curve	The duty point of the pump will move out or in the constant-pressure curve, depending on the heat demand in the system. The head (pressure) is kept constant, irrespective of the heat demand.
CC	Speed III	The pump runs at a constant speed and consequently on a constant curve. At speed III, the pump is set to run on the maximum curve under all operating conditions. Quick venting of the pump can be obtained by setting the pump to speed III for a short period.

WHML/XL AUTO internally controlled by the integrated pump controller

Proportional-pressure curve (PP1, PP2 or Pp3)

Proportional pressure is suitable in systems with relatively large pressure losses in the distribution pipes and in air-conditioning and cooling systems:

- Two-pipe heating systems with thermostatic valves and the following:
 - very long distribution pipes
 - strongly throttled pipe balancing valves
 - differential-pressure regulators
 - large pressure losses in the parts of the system through which the entire amount of water flows (for example boiler, heat exchanger and distribution pipe up to the first branching).
- Primary circuit pumps in systems with large pressure losses in the primary circuit.
- Air-conditioning systems with the following:
 - heat exchangers (fan coils)
 - cooling ceilings
 - cooling surfaces.

Characteristics and key benefits

- The head of the pump increases proportionally to the flow in the system.
 - Compensates for large pressure losses in the distribution pipes.
- Proportional-pressure control adjusts the pump performance to the actual flow demand in the system, but the pump performance follows the selected performance curve, PP1, PP2 or PP3. See fig. Three proportional pressure curves or settings where PP2 has been selected.

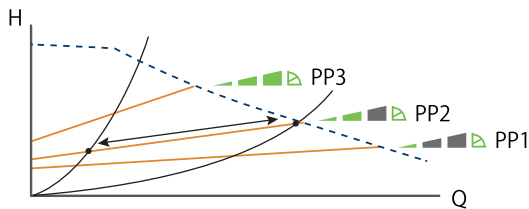

Three proportional-pressure curves or settings

Constant-pressure curve (CP1, CP2 or Cp3)

A constant pressure is advantageous in systems with relatively small pressure losses in the distribution pipes:

- Two-pipe heating systems with thermostatic valves:
 - dimensioned for natural circulation
 - small pressure losses in the parts of the system through which the entire amount of water flows (for example boiler, heat exchanger and distribution pipe up to the first branching).
 - modified to a high differential temperature between the flow pipe and the return pipe (for example district heating).
- Underfloor heating systems with thermostatic valves.
- One-pipe heating systems with thermostatic valves or pipe balancing valves.
- Primary circuit pumps in systems with small pressure losses in the primary circuit.

Characteristics and key benefits

- The pump pressure is kept constant, independent of the flow in the system.

Constant-pressure control adjusts the pump performance to the actual flow demand in the system, but the pump performance follows the selected performance curve, CP1, CP2 or CP3. See fig. Three constant-pressure curves or settings where CP1 has been selected.

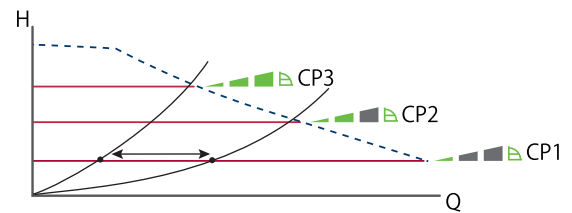

Three constant-pressure curves or settings

Constant curve (CC1, CC2 or CC3)

A constant curve is suitable for systems, where both a constant flow rate and a constant head are required, i.e.:

- Heat surfaces
- cooling surfaces
- heating systems with 3-way valves
- air-conditioning system with 3-way valve
- chiller pumps

Characteristics and key benefits

- If an external controller is installed, the pump is able to change from one constant curve to another, depending on the value of the external signal.
- Depending on your preferences, the pump can be controlled according to either a maximum or minimum curve.

Factory setting

The pumps have been factory-set to constant curve CC III. In constant-curve or constant-speed operation, the pump runs at a constant speed, independent of the actual flow demand in the system. The pump performance follows the selected performance curve, I, II or III. See fig. Three constant-curve or constant-speed settings where II has been selected.

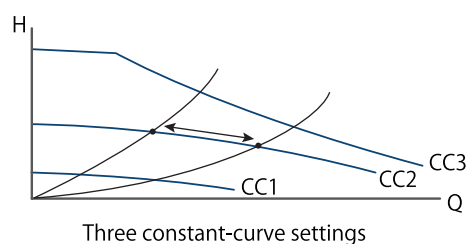

5.Communication and signals

Control principles

All WHML,WHMXL pumps can be controlled via a digital low-voltage pulse-width modulation (PWM) signal, which means that the speed of rotation depends on the input signal. The speed changes as a function of the input profile.

Control signals

Digital low-voltage PWM signal

The square-wave PWM signal is designed for a 100 to 4,000 Hz frequency range. The PWM signal is used to select the speed (speed command) and as feedback signal. The PWM frequency on the feedback signal is fixed at 75 Hz in the pump.

Duty cycle

$$d \% = 100 \times t/T$$

Example	Rating
T = 2 ms (500 Hz)	$U_{iH} = 4-24 \text{ V}$
t = 0.6 ms	$U_{iL} \leq 1 \text{ V}$
d % = $100 \times 0.6 / 2 = 30 \%$	$I_{iH} = 10 \text{ mA}$

Example

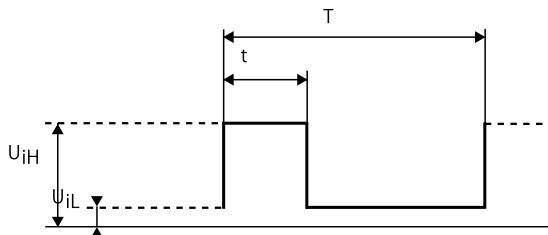

Fig. 1 PWM signal

Abbreviation	Description
T	Period of time [sec.]
d	Duty cycle [t/T]
U_{iH}	High-level input voltage
U_{iL}	Low-level input voltage
I_{iH}	High-level input current

Interface

WHML PWM,WHMXL PWM interface consists of an electronic part connecting the external control signal to the pump. The interface translates the external signal into a signal type that the micro processor can understand.

In addition, the interface ensures that the user cannot get into contact with dangerous voltage if touching the signal wires when power is connected to the pump.

Note :"Signal ref." is a signal reference with no connection to protective earth.

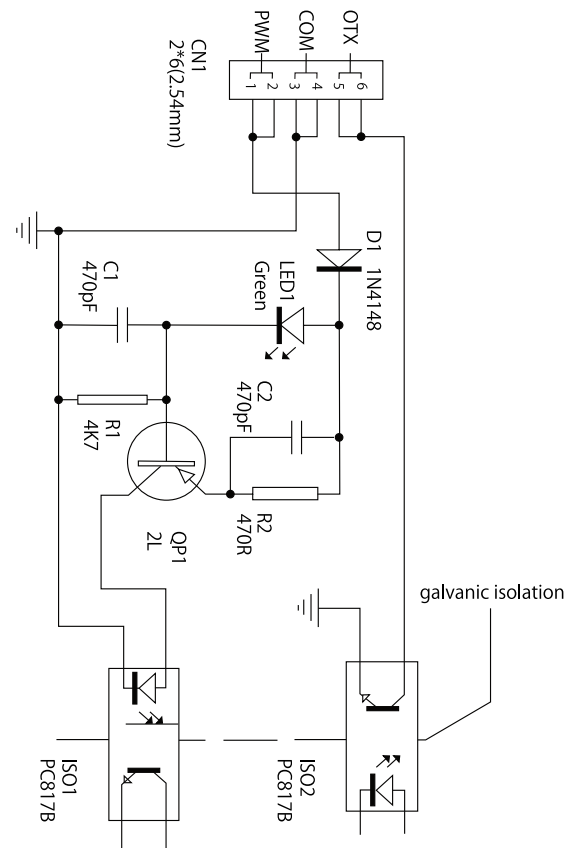

Fig. 2 Schematic drawing, interface

PWM input signal profile A (heating)

At high PWM signal percentages (duty cycles), a hysteresis prevents the pump from starting and stopping if the input signal fluctuates around the shifting point. At low PWM signal percentages, the pump speed is high for safety reasons. In case of a cable breakage in a gas boiler system, the pump continues to run at maximum speed to transfer heat from the primary heat exchanger. This is also suitable for heating pumps to ensure that the pumps transfer heat in case of a cable breakage.

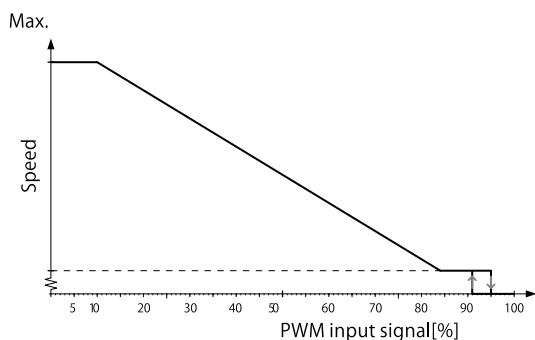

Fig. 3 PWM input profile A (heating)

PWM input signal [%]	Pump status
≤ 5	Maximum speed: max
$> 5 / \leq 84$	Variable speed: max to min
$> 84 / \leq 91$	Minimum speed: min
$> 91 / \leq 95$	Hysteresis area: on/off
$> 95 / \leq 100$	Standby mode: off

PWM input signal profile C (solar)

At low PWM signal percentages (duty cycles), a hysteresis prevents the pump from starting and stopping if the input signal fluctuates around the shifting point. Without PWM signal percentages, the pump will stop for safety reasons. If a signal is missing, for example due to a cable breakage, the pump will stop to avoid overheating of the solar thermal system.

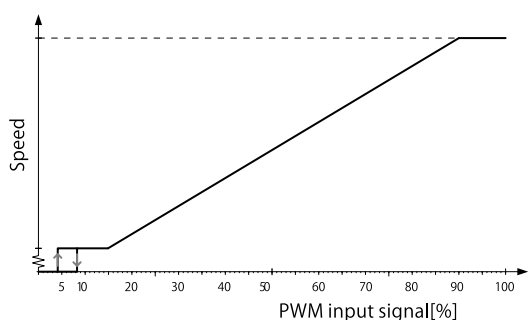

Fig. 4 PWM input profile C (solar)

PWM input signal [%]	Pump status
≤ 5	Standby mode: off
$> 5 / \leq 8$	Hysteresis area: on/off
$> 8 / \leq 15$	Minimum speed: min
$> 15 / \leq 90$	Variable speed: min. to max
$> 90 / \leq 100$	Maximum speed: max

PWM feedback signal - power consumption (standard)

The PWM feedback signal offers pump information like in bus systems:

- current power consumption (accuracy $\pm 2\%$ of PWM signal)
- warning
- alarm
- operation status

Alarms

Alarm output signals are available because some PWM output signals are dedicated to alarm information. If a supply voltage is measured below the specified supply voltage range, the output signal is set to 75%. If the rotor is blocked due to deposits in the hydraulics, the output signal is set to 90%, because this alarm has a higher priority.

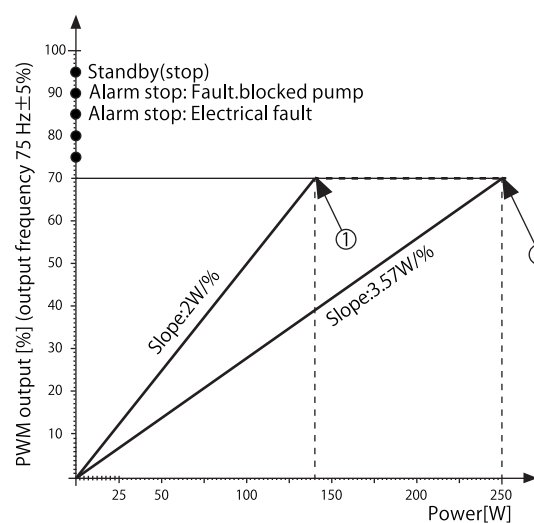

Fig. 5 PWM feedback signal, power consumption

Pos.	Type	Description
1	WHML	slope 2 W/%, saturation point, 140 W
2	WHMXL	slope 3.57 W/%, saturation point, 250 W

PWM output signal [%]	QT [s]	Pump info	DT [s]	Priority
95	0	Standby(STOP) by PWM signal	0	1
90	30	Alarm, stop, blocked error	12	2
85	0-30	Alarm, stop, electrical error	1-12	3
75	0	WARNING	0	5
0-70		0-140W (slope 2 W/%PWM)		6

Output frequency: 75 Hz \pm 5%

QT = qualification time, DT = disqualification time

PWM feedback signal - flow estimation(optional)

There is an option where the PWM feedback signal can also be used to indicate the flow of the pump on defined pump housings (e.g. cast iron inline) above a head of 1 m. The accuracy of the feedback signal is depending on the media, media temperature and operation point, but it gives an indication on the actual flow.

Example: The PWM output range between 0-70 % shows the flow between 0 and 4 m³/h with a slope of 0.057 m³/h / % PWM.

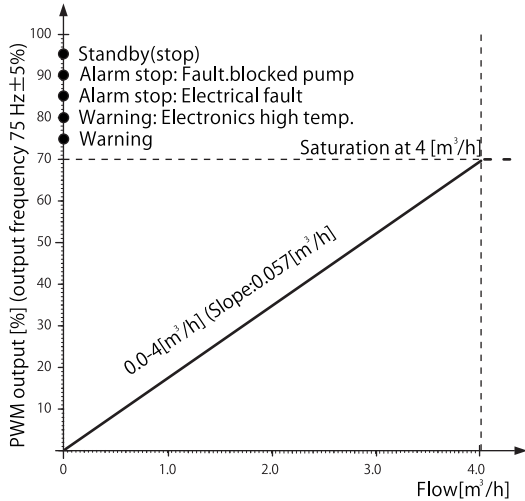

Fig. 6 PWM feedback signal - flow estimation

Data

Maximum rating	Symbol	Value
PWM frequency input with high-speed optocoupler	f	800-4000 Hz
Guaranteed standby power consumption		< 3 W
Rated input voltage - high level	U _{iH}	4-24 V
Rated input voltage - low level	U _{iL}	< 1 V
High-level input current	I _{iH}	< 10 mA
Input duty cycle	PWM	0-100%
PWM frequency output, open collector	f	75 Hz ± 5%
Accuracy of output signal regarding power consumption		± 2 % (of PWM signal)
Note: A PWM output signal below 5 % is too inaccurate for the calculation of the flow.		
Accuracy of output signal regarding flow:		
< 1 m ³ /h		± 0.1 m ³ /h
> 1 m ³ /h		± 0.2 m ³ /h
Output duty cycle	PWM	0-100%
Collector emitter breakdown voltage on output transistor	U _C	< 70 V
Collector current on output transistor	I _C	< 50 mA
Maximum power dissipation on output resistor	P _R	60 mW
Zener diode working voltage	U _Z	36 V
Maximum power dissipation in Zener diode	R _Z	500 mW

6. Operating panel

Setting the pump 3WHML AUTO, 3WHMXL AUTO

The user interface allows to select between 6 control curves in three control modes.

- 2 proportional pressure curves (PP1, PP2)
- 3 constant pressure curves (CP1, CP2, CP3)
- 1 Maximum power curve (CC)

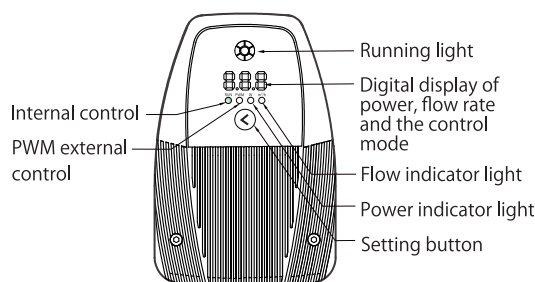

Running light	Indication	Cause
	No lights are on	The power is off. The pump is not running.
	Two opposite green indicator lights running in the direction of rotation of the pump	The power is on The pump is running.
	The middle red indicator light is permanently on.	Alarm. The pump has stopped.
	The six green indicator lights permanently on.	The pump is externally controlled.

Indicator light	Indication	Cause
	The light "RUN" turns green and is permanently on.	The pump is running in the modes CC, CP or PP.
	The light "PWM" turns green and is permanently on.	The pump is externally controlled by PWM signals.
	The power light "W" turns green and is permanently on.	The power of current duty point is 250W.
	The flow light "m ³ /h" turns green and is permanently on.	The flow rate of current duty point is 10m ³ /h.

Operating panel	Control mode
	Maximum power curve CC, factory setting
	Constant pressure curve CP1 (underfloor heating mode)
	Constant pressure curve CP2 (underfloor heating mode)
	Constant pressure curve CP3 (underfloor heating mode)
	Proportional pressure curve PP1 (radiator heating mode)
	Proportional pressure curve PP2 (radiator heating mode)

The first time, the pump starts with the factory presetting: max power curve CC control mode and real-time power feedback. With each push: switches between the control mode display and the power display of current duty point.

Control mode settings

- Push the setting button 5 seconds, the digital display starts flashing, the pump enters to the setting of the control modes.
- With each push, the setting changes: the control curve and mode are changed. If the button is not pushed for 90 seconds: the setting is adapted, the pump returns to the home interface.
- During operating, the display shows the selected control mode, the running light is permanently on and rotating in the direction of the pump rotation, the pump is running with selected curve and mode.
- Plug the signal cable, the pump goes to the external control, the setting button is invalid, the user is unable to set anything on the interface.

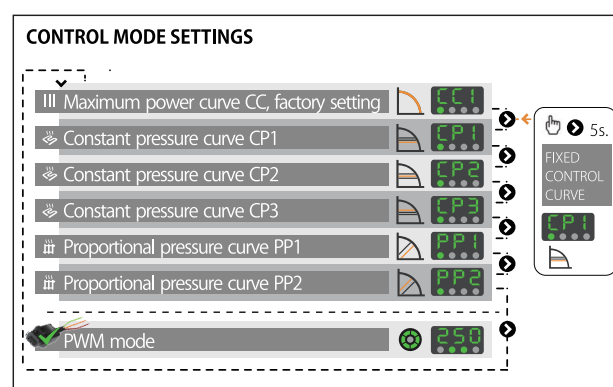

Power and flow display settings

- Push the setting button 5 seconds, the digital display starts flashing.
- Push the setting button another 5 seconds, the pump enters to the setting of the power and flow display.
- With each push, the setting changes: the display is changed between power and flow. If the button is not pushed for 90 seconds: the setting is adapted, the pump returns to the home interface.
- During operating, the interface shows the real-time data of the selected display, the running light is permanently on and rotating in the direction of pump rotation.

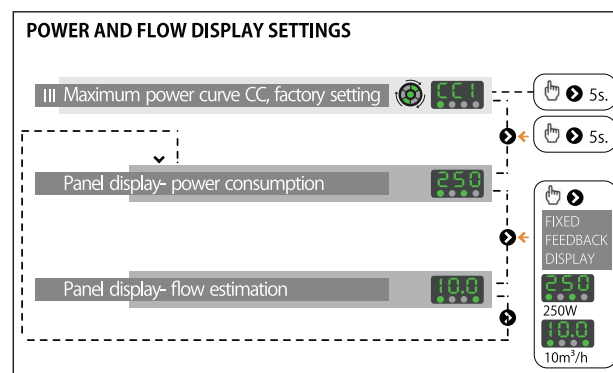

7. Construction

Exploded view 3WHML,3WHMXL

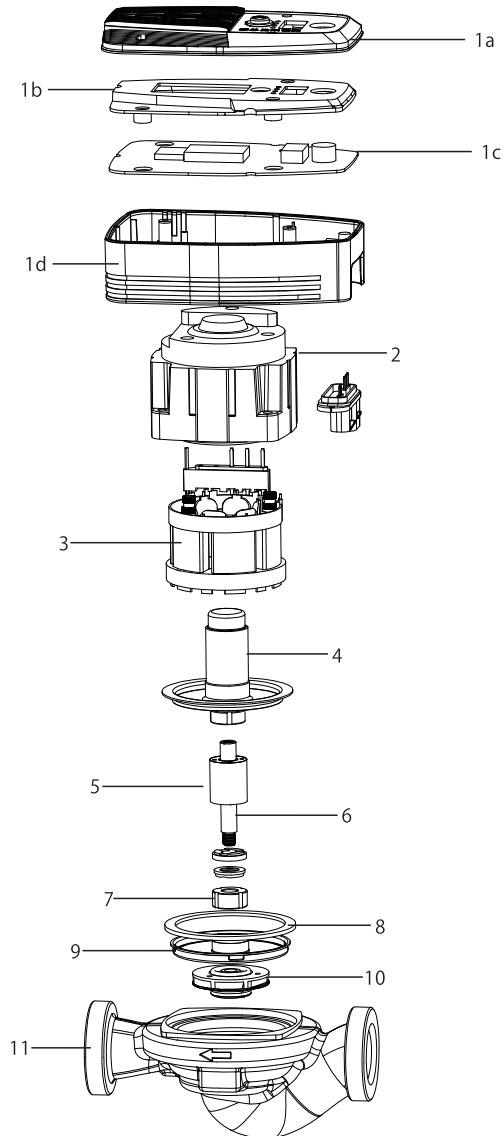

Material specification

Pos.	Component	Material
1a	Heat sink with cooling pad	Aluminum alloy ACD12
1b	Control box cover	Composite PC-V0 + GF30%
1c	Control box electronics	PCB with SMD components
1d	Control box housing	PC-V0 + GF30%
2	Stator housing	Aluminum alloy ACD12
3	Stator winding	Copper wire
	Stator lamination	Laminated iron
4	Rotor Can	Stainless steel SUS304
5	Rotor stack	Laminated iron
	Rotor magnet	NdFeB or Ferrite
	Rotor cladding	Stainless steel SUS304
6	Shaft	Ceramic
7	Thrust bearing	Graphite
8	Gasket	EPDM
9	Bearing plate	Stainless steel SUS304
10	Impeller	PES + GF30%
11	Pump body	Cast iron/Plastic
		/Stainless steel SUS304

Description of components

WHML,WHMXL pumps are of the canned-rotor type, that is pump and motor form an integral unit without shaft seal and with only one gasket for sealing and four screws for fastening the stator housing to the pump housing. The bearings are lubricated by the pumped medium.

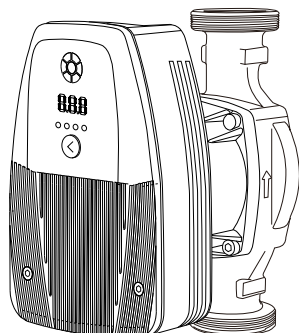

Fig. 7 Example, 3WHML

Motor

The efficiency of the 4-pole, synchronous, electronically commutated permanent-magnet (ECM/PM) motor type is considerably higher compared to a conventional asynchronous squirrel-cage motor.

The PM motor is designed according to the canned-rotor principle. The design of the mechanical motor components has mainly focused on these features:

- robustness achieved through efficient protection of loaded components.
- simple design meaning as few components as possible, each with several functions.
- high efficiency due to permanent magnets and low-friction bearings.

The motor is cooled by the pumped medium which reduces the sound pressure level to a minimum. Being software-protected the pump requires no further motor protection.

Pump housing

As standard, the pump housing is available in electrocoated cast iron with threaded inlet and outlet ports. The pump housing is of the in-line type. The stainless-steel neck ring is pressed into the pump housing to minimise the amount of liquid running from the outlet side of the impeller to the inlet side.

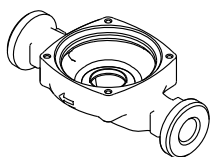

Fig. 14 Pump housing

Stator and windings

The WHML,WHMXL pumps have a three-phase stator. These pumps are designed for pumping very cold liquids (down to -10°C). In such applications, condensation may occur in the stator housing. To protect the stator, the copper wires are provided with reinforced insulation.

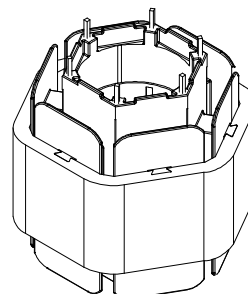

Fig. 8 Stator

Shaft with rotor

WHML,WHMXL shaft is made of ceramics. The rotor core is fitted with ferrite or neodymium permanent magnets. The rotor is encapsulated in a thin stainless-steel cladding welded to the end covers. To avoid precipitation of calcium in the radial bearings, the shaft has been plunge-ground at the journals. It has a through-going hole to ensure good lubrication and cooling of the upper bearing. Air in the rotor chamber escapes into the system through the through-going holes of the shaft.

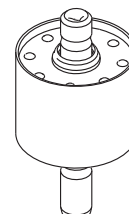

Fig. 9 Shaft with rotor

Rotor can

The drawn stainless-steel rotor can holds the ground and honed upper radial bearing at the top.

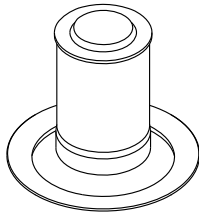

Fig. 10 Rotor can

Bearing plate

WHML,WHMXL bearing plate is made of stainless steel. The ground and honed inner radial bearing is pressed into the bearing plate. Thanks to the relatively large bearing plate surface, the motor heat is effectively carried away by the pumped medium.

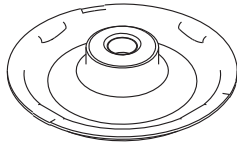

Fig. 11 Bearing plate

Thrust bearing

The thrust bearing is fitted to the shaft in a flexible suspension. In combination with the bearing plate, the thrust bearing prevents forces from being transmitted axially to rotor and rotor can.



Fig. 12 Thrust bearing

Impeller

The composite PES impeller is of the radial type with curved blades. The impeller is secured to the shaft with a split cone. The impeller, shaft with rotor and bearing plate are assembled in one unit to eliminate possible misalignment in the bearings.

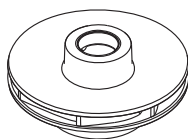

Fig. 13 Impeller

Control box

The control box is made of black composite material with an aluminium heat sink. It contains the PCBs for internal power supply and communication.

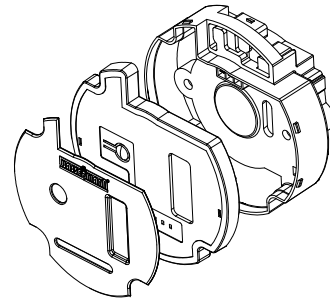

Fig. 15 Control box for 1WHM

8. Installation



Installation must be carried out by trained persons in accordance with local regulations.

Pumped liquids



The pump must not be used for circulation of flammable liquids such as diesel oil and petrol.



Risk of malfunction or damage when inhibitors or additives are added to the pumped liquids.

WHML,WHMXL pumps are suitable for the following liquids:

- Clean, thin, non-aggressive and non-explosive liquids, not containing solid particles or fibres.
- In heating systems, the water must meet the requirements of accepted standards on water quality in heating systems.
- The pH must be between 8.2 and 9.5. The minimum value depends on the water hardness and must not be below 7.4 at 4°dH(0.712 mmol/l).
- The electrical conductivity at 25°C must be ≥ 10 microS/cm.
- For drinking water systems, approved housings must be used, such as stainless steel N and plastic P. These pumps and their components in contact with water are approved by WRAS(GB), ACS(FR), KTW(DE)and DIN DVGW W270 (DE).
- In domestic hot-water systems, the pump must be used only for water with a degree of temporary hardness of less than 3 mmol/l CaCO₃(16.8 dH). To avoid lime problems in hard waters, the medium temperature must not exceed 65°C.
- The water quality of test beds for the final production tests of complete heating appliances including pump must be observed to avoid calcification or biofilm formation during a longer storage period.
- Solar media as used in typical solar thermal systems containing up to 50 Vol % of antifreeze media.
- Mixtures of water with antifreeze media such as glycol or ethanol(down to-10°C with a validated temperature profile) with a kinematic viscosity lower than 15 mm²/s (15 cSt).

Antifreeze media containing glycol

When selecting a pump, the viscosity of the pumped liquid must be taken into consideration. Depending on the type of glycol, the mixture and the liquid temperature, the viscosity increases differently compared to water as a medium. This will influence the pressure loss of the system as well as the efficiency, performance and load of the pump. As the pump is controlled by a power limitation function that protects against overload, the maximum curve might be lower.

Example:

If the water-glycol mixture is 50 % and the liquid temperature is +2°C the viscosity is 15 cSt: The maximum head falls 1.0 to 1.5m compared to 100 % water at 60°C(at the same flow). Performance curves measured with a medium containing glycol at higher viscosity than water are different from the water curves in this data booklet and can be taken into account by adding these mark-up factors to the required duty point:

Pumped liquid at -7°C	Viscosity [mm ² /s]	Density [kg/m ³]	H _{mark up} [%]	Q _{mark up} [%]	P _{mark up} [%]
Ethylene glycol					
50 %	10.20	1083	7	10	18
30 %	5.18	1054	3	7	9
25 %	4.37	1046	2	5	8
Propylene glycol					
50 %	26.90	1056	14	15	19
30 %	9.71	1038	7	8	8
25 %	7.34	1033	4	5	7
Ethanol					
50 %	10.20	932	4	10	2
30 %	11.00	972	4	8	3
25 %	9.61	980	4	7	4

Mechanical installation



Mechanical installation must be carried out by trained persons in accordance with local regulations.



The pump must always be installed with horizontal motor shaft within $\pm 5^\circ$.



Arrows on the pump housing indicate the liquid flow direction through the pump. The pump is designed to be installed with horizontal shaft pumping upwards, downwards or horizontally.

For mounting dimensions see the data sheets.

- The pump must be installed in the system in such a way that no major amount of air flowing through or gathering in the pump housing affects the pump when it is out of operation.
- If an additional non-return valve is installed in the flow pipe, there is a high risk of dry-running, because the air cannot pass the valve.
- It must be possible to vent the system at the highest part of each system segment.
- Permanent venting is recommended.

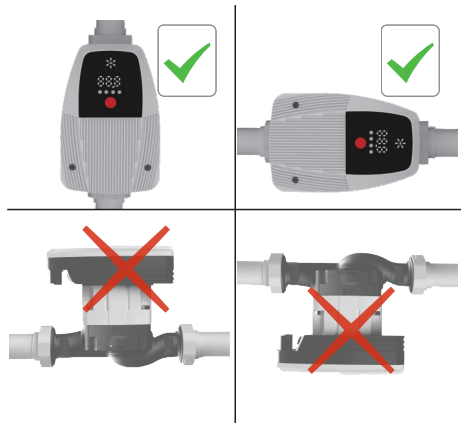

Fig. 16 Control box positions

Insulation

When insulating the pump, the control box (especially the cooling cover) must not be covered to allow cooling by the surrounding air.

If the pump is installed in a cabinet or fitted with insulation shells, the inside air temperature must not be higher than 55°C during operation. It must not cover the pump head.

Mechanical specifications

Ambient temperature

The ambient temperature must not exceed 55°C (near the pump surface).

Relative humidity

The relative humidity inside control box must not exceed 95%. Condensation is acceptable if the cables on the control box point downwards.

Liquid temperature

- Max. 95°C at 55°C ambient temperature (continuously)
- Max. 110°C for short periods or at low load
- Min. -10°C (see validated temperature profile)

Note: For further lifetime evaluation the temperature profile must be defined.

System pressure

Max. 1.0 Mpa (10 bar) with cast iron or stainless steel housings.
Max. 0.6 Mpa (6 bar) with plastic housings.

Minimum inlet pressure

To avoid cavitation noise and damage to the pump bearings, the following minimum pressures are required at the inlet port.

Liquid temperatur	75° C	95° C	110° C
Minimum inlet pressure	0.01 Mpa 0.10 bar	0.05 Mpa 0.50 bar	0.10 Mpa 1.00 bar

Electrical installation



DANGER Electric shock

- ▲ Death or serious personal injury
- ▶ Before starting any work at the pump, switch off the power supply. Make sure that the power supply cannot be switched on accidentally.



All electrical connections must be carried out by a qualified electrician in accordance with local regulations.



The pump is not a safety component and cannot be used to ensure functional safety in the final appliance.

- The pump requires no external motor protection.
- Check that the supply voltage and frequency correspond to the values stated on the nameplate.
- The pump must not be used with an external speed control which varies the supply voltage.
- If an earth leakage circuit breaker is used, check which type it is.
- If an external relay is used, check if it can stand the inrush current.

Supply voltage

EU version: 1 x 230 V +10 %/- 15 %, 50/60 Hz.

The WHML,WHMXXL pumps are externally controlled via PWM signal or internally speed-controlled by a frequency converter. Therefore, the pumps must not be used with an external speed control which varies the supply voltage, for example phase-cut or pulse- cascade control.

Reduced supply voltage

WHML,WHMXXL with PWM control: If the voltage falls below the specified voltage range $\leq 155\text{VAC}$, a low voltage warning is sent via PWM return signal.

Earth leakage circuit breaker (ELCB)



DANGER Electric shock

- ▲ Death or serious personal injury
- ▶ If national legislation requires a Residual Current Device(RCD) or equivalent in the electrical installation, this must be type A or better, according to the nature of the pulsating DC leakage current.

If the pump is connected to an electric installation that uses an earth leakage circuit breaker (ELCB) as additional protection, this circuit breaker must trip when earth fault currents with DC content (pulsating DC) occur.

The earth leakage circuit breaker must be marked with the first (type A) or both (type B) of the symbols shown below:

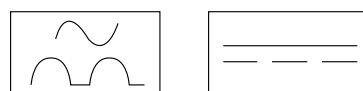

Fig. 17 Symbol on earth leakage circuit breaker

Leakage current

The pump mains filter causes a leakage current to earth during operation.

Leakage current: $< 3.5\text{ mA}$.

Inrush current

All electronic pumps contain electronic units that must be protected by filters including capacitors and ECM pumps frequency converters with AC/DC rectifiers containing capacitors to equalize the waves. This is not the case in most asynchronous pumps.

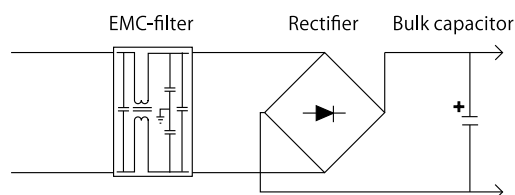

Fig. 18 Rectification of VAC voltage to DC voltage

The load of electronically commutated motors(ECM) behaves as a capacitive load and not as a motor load like in a standard pump. At start the capacitor is unloaded. Hereby the amplitude of the current peak depends on the grid impedance until the capacitor is charged. The faster the capacitor is charged, the higher amplitude, and the faster the pump can be started. After this period of time, the current will drop to the rated current.

Definition: Inrush current is the current peak charging the capacitors in the electronics when the supply voltage is connected.

Power supply connection

3WHML,3WHMXL Power plug with cable

1m, 3×0.75 mm²,PVC,VDE

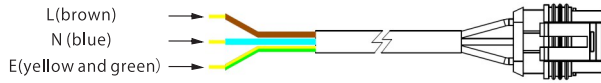

Signal cable

WHML AUTO, WHMXL AUTO pumps are internally speed-controlled and have no signal cable connection. We recommend to order these pump types with signal blind plug. WHM PWM pumps are externally speed-controlled. To enable pump control, a signal cable is required, otherwise the pump always runs at maximum speed.



SOLAR WHM pumps do not run without signal (PWM profile C for solar).

The signal cable has three leads, signal input, signal output and signal reference. The optional signal cable can be supplied with the pump as an accessory.

3WHML,3WHMXL signal cable

1m, 3×0.3mm², PVC

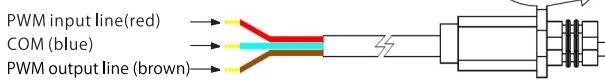

Connect the signal wires to the correct poles. Otherwise the pump might be damaged.

PWM wiring diagram

No.	Signal	Function
1	PWM IN	Pump PWM input signal. Input PWM duty cycle range: 0~100%, input signal frequency range: 800Hz~4000Hz. Maximum input voltage range: 4~24V. Recommended external controller output high level: 4-10V, output low level: <1V
2	COM	PWM reference
3	PWM OUT	Pump PWM output signal. Output PWM duty cycle range: 0~100%, output signal frequency is 75Hz, collector output (i.e. OC gate output) transistor withstand voltage limit is 30V, the controller needs to connect a pull-up resistor to the power supply (such as 5V), recommended resistance value is 4.7k Ω. Otherwise, the upper computer will not receive the PWMOUT signal.

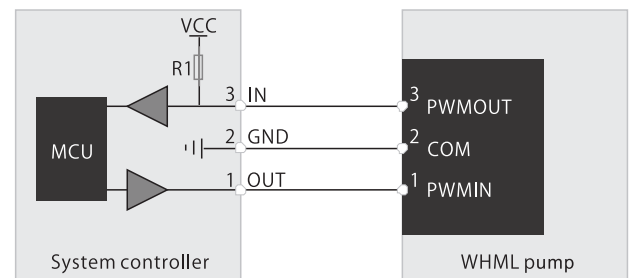

Fig. 19 Internally controlled

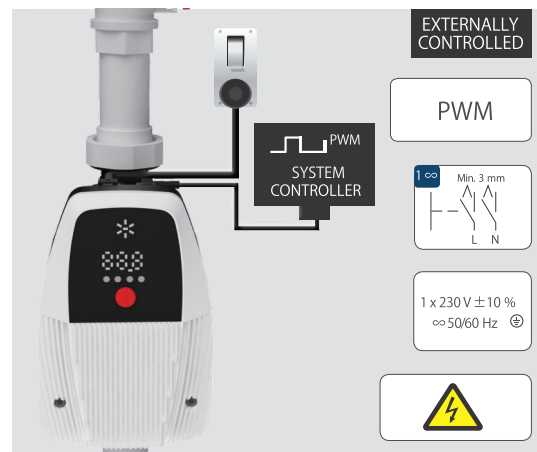

Fig. 20 Externally controlled

9. Startup

Before you start the WHML,WHMXL pump:

1. Mount the pump in the right way.
2. Check that the unions are tightened.
3. Check that the valves are opened.
4. Fill the system and vent it above the pump.
5. Check if the required minimum inlet pressure is available at the pump inlet.
6. Switch on the power supply.
7. If the pump is externally controlled: Check if the external controller sends a signal that controls the speed or that might have stopped the pump.
8. If the pump is internally controlled: The pump starts with factory presetting. Change the setting if necessary (see User interface).



Do not start the pump, until the system has been filled with liquid and vented.



WHML,WHMXL pumps are self-venting and do not have to be vented before startup. Air inside the pump is transported by the liquid into the system shortly after startup.

Hint for installers:

- Heating systems must be flushed before startup. After filling the system for the first time, the pump must run for approx. 1 hour before a long-term stop.
- Inhibitors and additives increase the risk of malfunction of the pump.
- If filters are installed, they must be monitored and maintained thoroughly.

Warning: This appliance can be used by children aged from 8 years and above and persons with reduced physical, sensory or mental capabilities or lack of experience and knowledge, if they have been given supervision or instruction concerning use of the appliance in a safe way and understand the hazards involved. Children shall not play with the appliance. Cleaning and user maintenance shall not be made by children without supervision.

10. Service



DANGER **Electric shock**

- ▲ Death or serious personal injury
- ▶ Before starting any work at the pump, switch off the power supply. Make sure that the power supply cannot be switched on accidentally.
- ▶ Be aware that capacitors will be live up to 30 seconds after the power supply has been switched off.



DANGER **Electric shock**

- ▲ Death or serious personal injury
- ▶ Before dismantling the complete pump set, switch off the power supply at least 5 minutes prior to commencing work and ensure that it cannot be switched on again unintentionally.



DANGER **Electric shock**

- ▲ Death or serious personal injury
- ▶ When running in reverse, the pump acts as a generator and creates hazardous induction voltage at the motor terminals.
- ▶ Prevent the fluid from flowing back by closing the shut-off valves.



WARNING **Strong magnetic field in the rotor area**

- ▲ Danger of death for persons with pacemaker.
- ▶ Keep a safety distance of at least 0.3 m during disassembly.



WARNING **Toxic material**

- ▲ Death or serious personal injury
- ▶ Decontaminate pumps which handle fluids posing a health hazard.



CAUTION **Hot surface**

- ▲ Minor or moderate personal injury.
- ▶ Before starting to work on the pump, let the pump casing cool down to ambient temperature.



All service work must be carried out by an instructed service technician.



Before dismantling the pump, drain the system, or close the isolating valves on either side of the pump.

Cleaning

If the impeller or pump housing has to be cleaned from impurities, proceed as follows:

1. Drain the system or close the isolating valves. —Be aware of hot water.
2. Remove the screws that hold the pump head.
3. Check impeller and pump housing and remove the impurities.
4. Place the pump head in the desired position, fit the screws and tighten the screws securely.

3WHML,3WHMXL alarm type and display

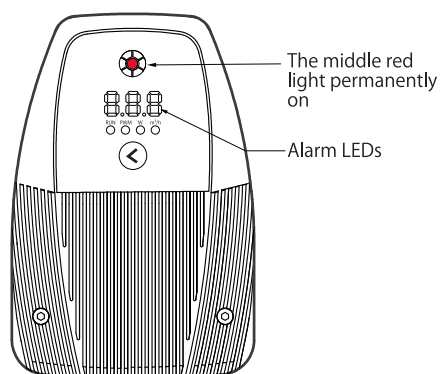

Operating panel	Fault description
E1	Over current, short circuit or water leakage in the coil
E2	The pump fails to start up due to idling
E3	Impeller or rotor is blocked by the water scale or the impurities
E4	Input voltage < 155VAC
E5	IPM is over heated, > 103°C
E6	Input voltage > 290VAC
E7	The pump is out of control, software abnormal
E8	UVW lack of phase

The operating panel is designed with one running light and one alarm LED window.

If the circulator pump has detected one or more alarms or warnings, the middle red light is permanently on, the LED window indicates the type of the alarm or warning.

If multiple alarms are activated simultaneously, the alarm LED only indicates the highest priority error. Priorities are defined according to the sequence in the table. After troubleshooting, the running light turns green and is permanently rotating.

Fault description

Fault	Description
Over current	The output current of the controller is too high, in order to avoid the damage to electronics, the controller will stop running. This fault is caused by 1. A short circuit in the motor coil, 2. Water leakage in the motor, 3. The controller is defective.
Startup failure	During the power on startup, the pump can not start smoothly, fails to startup or the speed is far below the set value. The cause of such failures can be 1. The controller is defective, 2. The pump is blocked by impurities.
Blocked	The rotation speed is far below the set value, it is considered that the pump is blocked. This type of fault is usually caused by the impeller being stuck by impurities or scale.
Under voltage	The current AC input voltage is too low ($\leq 155\text{VAC}$), it causes the abnormal operation of the controller. When the voltage difference meets the minimum voltage value of the controller, the fault will be removed automatically and the pump will run in the mode before the shutdown.
Over heated	The temperature of the pump is too high ($> 103^\circ\text{C}$), the controller will stop the pump automatically. When the temperature drops to a certain level, the fault will be removed automatically and the pump will run in the mode before the shutdown.
Over voltage	The AC input voltage is too high ($\geq 290\text{V}$), it causes the abnormal operation of the controller. When the voltage difference drops 5%, the fault will be removed automatically and the pump will run in the mode before the shutdown.

Fault finding

Fault	Cause	Remedy
1.Pump is not running. No power supply.	System is switched off.	Check the system controller.
	A fuse in the installation is blown.	Replace the fuse.
	The circuit breaker has tripped.	Check the power connection and switch on the circuit breaker.
	Power supply failure.	Check the power supply.
2.Pump is not running. Normal power supply.	Controller is switched off.	Check the controller and its settings.
	Pump is blocked by the impurities or water scale.	Unscrew the pump housing , remove the impurities, or wash the rotor assembly.
	Pump is defective.	Replace the pump.
3.Pump runs at maximum speed and cannot be controlled.	No signal from signal cable.	Check if the cable is connected to the controller. If it is, replace the cable.
4.Noise in the system.	There is air in the system.	Vent the system.
	Differential pressure is too high.	Reduce the pump performance at the pump or external controller.
5.Noise in the pump.	There is air in the pump.	Let the pump run. The pump vents itself over time.
	Inlet pressure is too low.	Increase the system pressure or check the air volume in the expansion tank, if installed.
6.Insufficient flow.	Pump performance is too low.	Check the external controller and the pump settings.
	Hydraulic system is closed or system pressure is insufficient.	Check the non-return valve and filter. Increase the system pressure.

11. Product Dimensions

3WHML,3WHMXL Dimensions

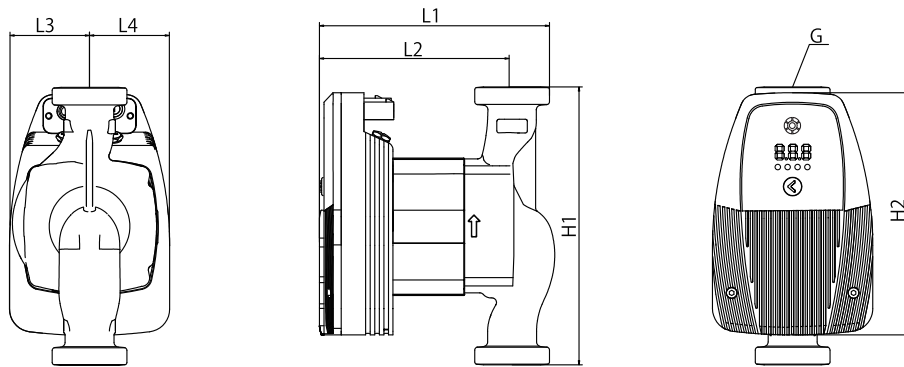

PUMP type	Dimensions[mm]						
	L1	L2	L3	L4	H1	H2	G
WHML 25-xx/130	148	125	51	52	130	159	G1 1/2
WHML 25-xx/180	151	124	52	52	182	159	G1 1/2
WHML 32-xx/180	151	121.5	56	56	180	159	G2
WHMXL 25-xx/180	151	124	52	52	182	159	G1 1/2
WHMXL 32-xx/180	151	121.5	56	56	180	159	G2

3WHMXL/F Dimensions

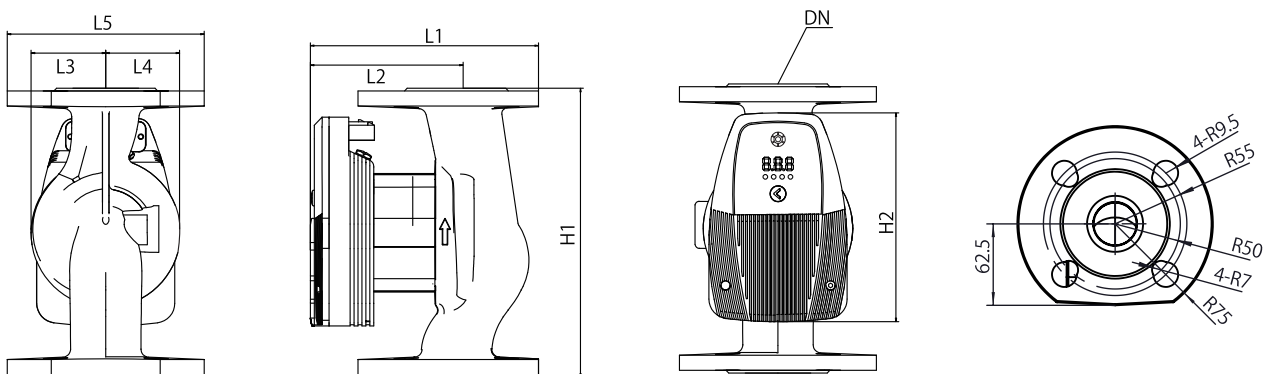

PUMP type	Dimensions[mm]							
	L1	L2	L3	L4	L5	H1	H2	DN
WHMXL 32-80F/220	173	116	57	57	150	220	159	DN32
WHMXL 32-100F/220	173	116	57	57	150	220	159	DN32
WHMXL 32-120F/220	173	116	57	57	150	220	159	DN32
WHMXL 40-80F/250	176	117	57	57	150	250	159	DN40
WHMXL 40-100F/250	176	117	57	57	150	250	159	DN40
WHMXL 40-120F/250	176	117	57	57	150	250	159	DN40

12. Performance curves and technical data

WHML AUTO series 1 × 230 V, 50/60 Hz

Pump Curve

WHML 25-105 AUTO

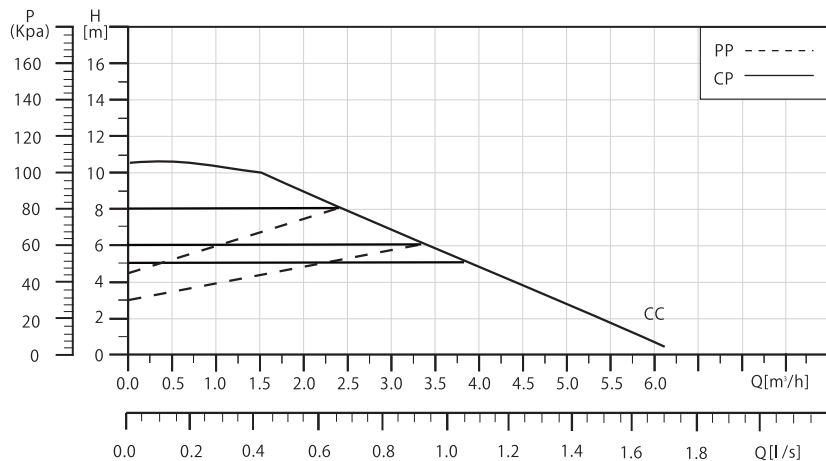

EEl ≤ 0.23

Mode	Max. head
CP1	5m
CP2	6m
CP3	8m
PP1	6m
PP2	8m
CC	10.5m

Electrical data, 1 x 230 V, 50 Hz, 3900 rpm

Speed	P ₁ [W]	I _{1/1} [A]
Min	20	0.25
Max	140	1.10

WHML 32-105 AUTO

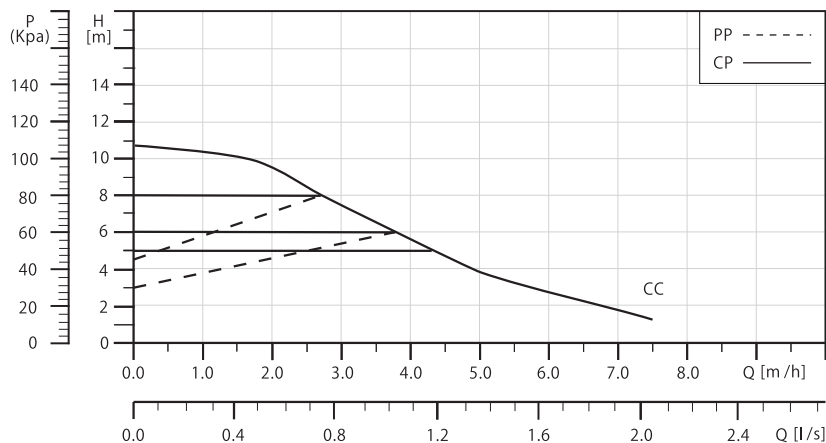

EEl ≤ 0.23

Mode	Max. head
CP1	5m
CP2	6m
CP3	8m
PP1	6m
PP2	8m
CC	10.5m

Electrical data, 1 x 230 V, 50 Hz, 3950 rpm

Speed	P ₁ [W]	I _{1/1} [A]
Min	20	0.25
Max	140	1.10

WHML AUTO series 1 × 230 V, 50/60 Hz

Pump Curve

WHML 25-125 AUTO

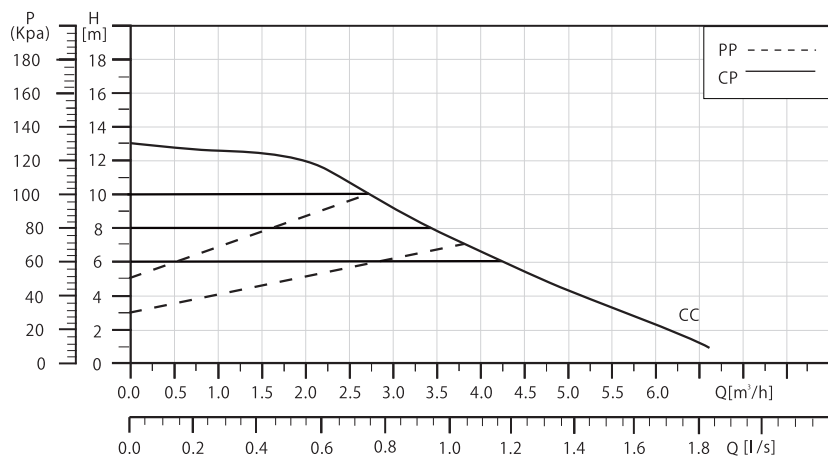

EEI ≤ 0.23

Mode	Max. head
CP1	6m
CP2	8m
CP3	10m
PP1	7m
PP2	10m
CC	13m

Electrical data, 1 x 230 V, 50 Hz, 4000 rpm

Speed	P ₁ [W]	I _{1/1} [A]
Min	22	0.29
Max	180	1.50

WHML 32-125 AUTO

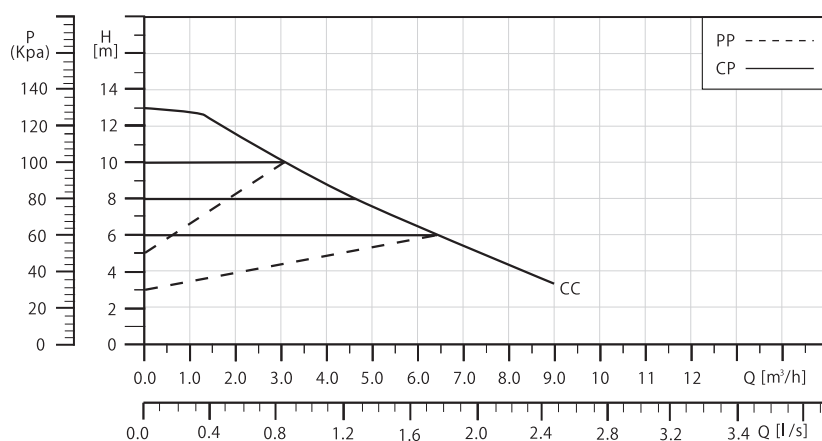

EEI ≤ 0.23

Mode	Max. head
CP1	6m
CP2	8m
CP3	10m
PP1	6m
PP2	10m
CC	13m

Electrical data, 1 x 230 V, 50 Hz, 4350 rpm

Speed	P ₁ [W]	I _{1/1} [A]
Min	22	0.29
Max	180	1.50

WHML AUTO series 1 × 230 V, 50/60 Hz

Pump Curve

WHML 25-140 AUTO

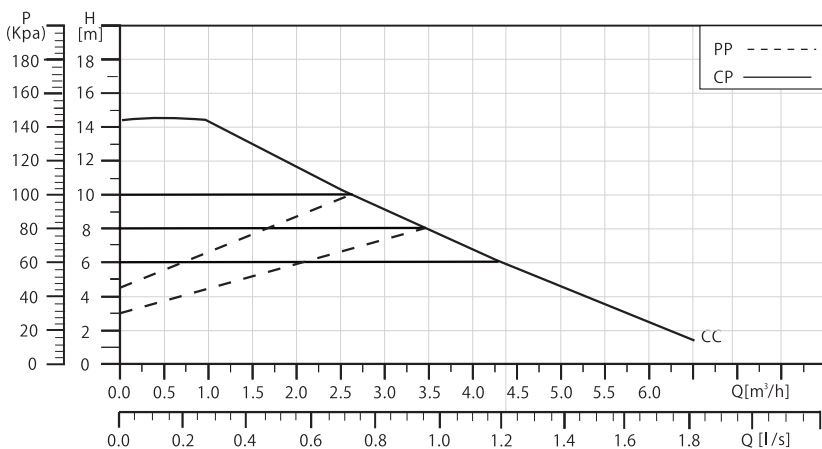

EEI ≤ 0.23

Mode	Max. head
CP1	6m
CP2	8m
CP3	10m
PP1	8m
PP2	10m
CC	14m

Electrical data, 1 x 230 V, 50 Hz, 4400 rpm

Speed	P ₁ [W]	I _{1/1} [A]
Min	22	0.29
Max	190	1.50

WHML 32-140 AUTO

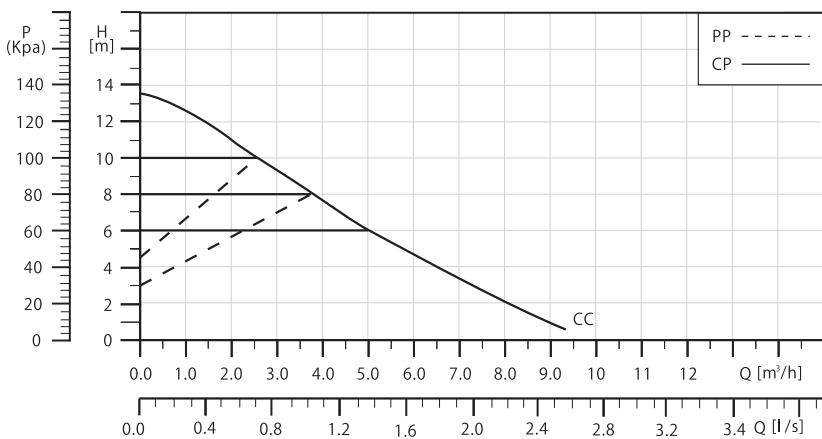

EEI ≤ 0.23

Mode	Max. head
CP1	6m
CP2	8m
CP3	10m
PP1	8m
PP2	10m
CC	13.3m

Electrical data, 1 x 230 V, 50 Hz, 4500 rpm

Speed	P ₁ [W]	I _{1/1} [A]
Min	22	0.29
Max	190	1.50

WHMXL AUTO series 1 × 230 V, 50/60 Hz

Pump Curve

WHMXL 25-110 AUTO

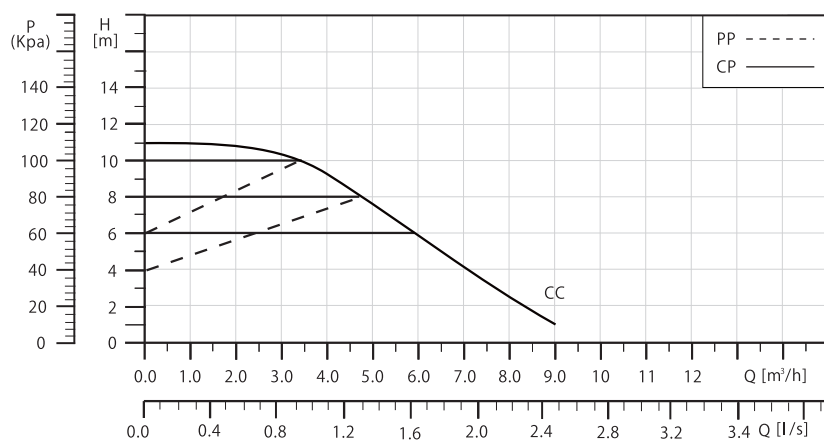

EEI ≤ 0.23

Mode	Max. head
CP1	6m
CP2	8m
CP3	10m
PP1	8m
PP2	10m
CC	11m

Electrical data, 1 x 230 V, 50 Hz, 4850 rpm

Speed	P ₁ [W]	I _{1/1} [A]
Min	27	0.35
Max	250	2.50

WHMXL 32-110 AUTO

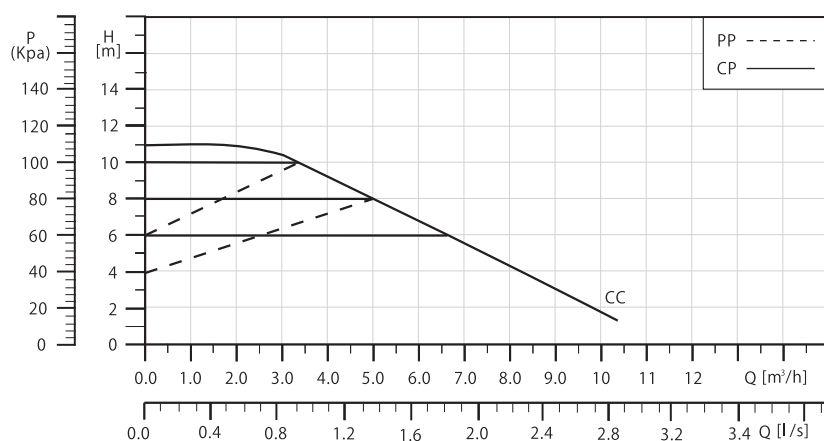

EEI ≤ 0.23

Mode	Max. head
CP1	6m
CP2	8m
CP3	10m
PP1	8m
PP2	10m
CC	11m

Electrical data, 1 x 230 V, 50 Hz, 4800 rpm

Speed	P ₁ [W]	I _{1/1} [A]
Min	27	0.35
Max	250	2.50

WHMXL AUTO series 1 × 230 V, 50/60 Hz

Pump Curve

WHMXL 25-120 AUTO

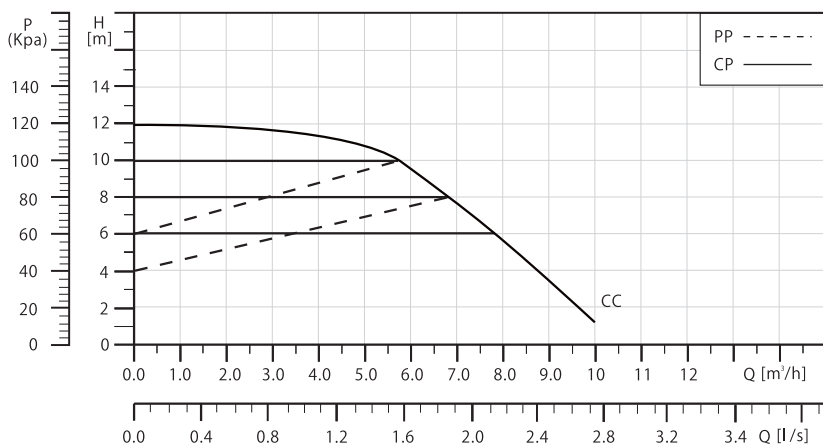

EEI ≤ 0.23

Mode	Max. head
CP1	6m
CP2	8m
CP3	10m
PP1	8m
PP2	10m
CC	12m

Electrical data, 1 x 230 V, 50 Hz, 5000 rpm

Speed	P ₁ [W]	I _{1/1} [A]
Min	27	0.35
Max	350	3.00

WHMXL 32-120 AUTO

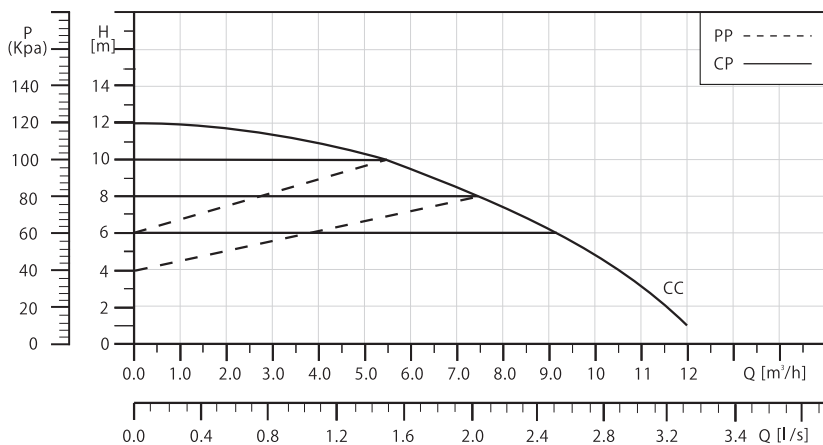

EEI ≤ 0.23

Mode	Max. head
CP1	6m
CP2	8m
CP3	10m
PP1	8m
PP2	10m
CC	12m

Electrical data, 1 x 230 V, 50 Hz, 5000 rpm

Speed	P ₁ [W]	I _{1/1} [A]
Min	27	0.35
Max	350	3.00

WHMXL AUTO series 1 × 230 V, 50/60 Hz

Pump Curve

WHMXL 25-160 AUTO

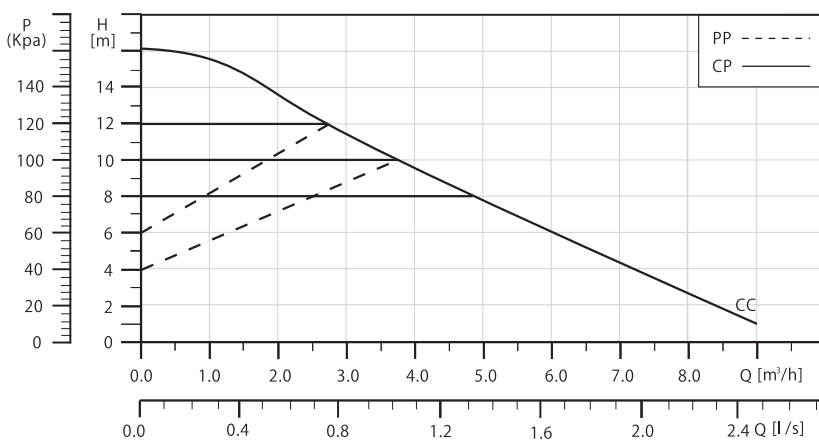

EEI ≤ 0.23

Mode	Max. head
CP1	8m
CP2	10m
CP3	12m
PP1	10m
PP2	12m
CC	16m

Electrical data, 1 x 230 V, 50 Hz, 5000 rpm

Speed	P ₁ [W]	I _{1/1} [A]
Min	27	0.35
Max	250	2.50

WHMXL 32-160 AUTO

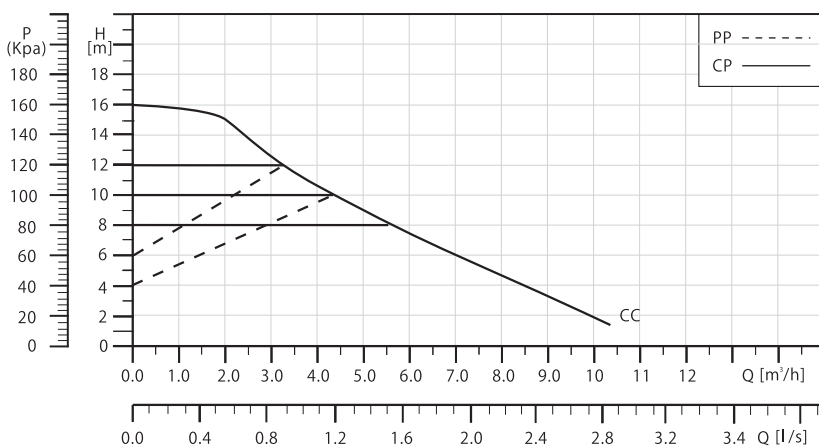

EEI ≤ 0.23

Mode	Max. head
CP1	8m
CP2	10m
CP3	12m
PP1	10m
PP2	12m
CC	16m

Electrical data, 1 x 230 V, 50 Hz, 4900 rpm

Speed	P ₁ [W]	I _{1/1} [A]
Min	27	0.35
Max	250	2.50

WHMXL AUTO series 1 × 230 V, 50/60 Hz

Pump Curve

WHMXL 25-180 AUTO

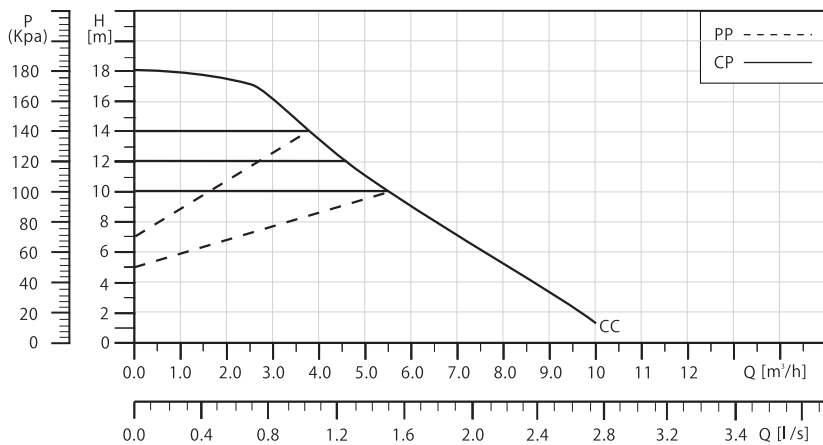

EEI ≤ 0.23

Mode	Max. head
CP1	10m
CP2	12m
CP3	14m
PP1	10m
PP2	14m
CC	18m

Electrical data, 1 x 230 V, 50 Hz, 5250 rpm

Speed	P ₁ [W]	I _{1/1} [A]
Min	27	0.35
Max	350	3.00

WHMXL 32-180 AUTO

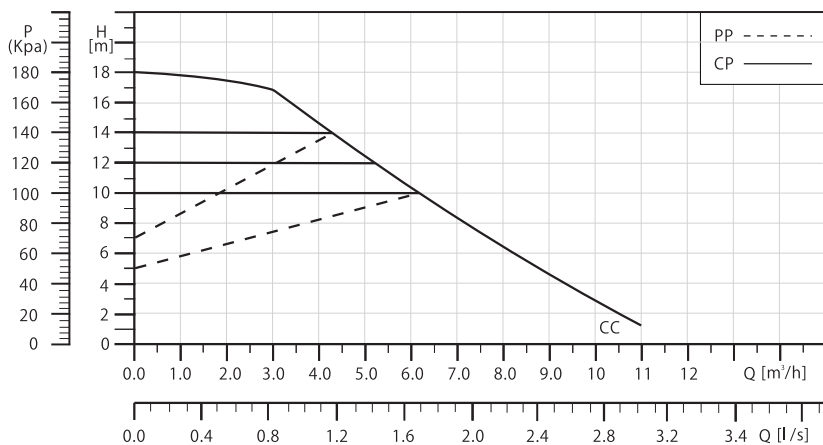

EEI ≤ 0.23

Mode	Max. head
CP1	10m
CP2	12m
CP3	14m
PP1	10m
PP2	14m
CC	18m

Electrical data, 1 x 230 V, 50 Hz, 5200 rpm

Speed	P ₁ [W]	I _{1/1} [A]
Min	27	0.35
Max	350	3.00

WHMXL AUTO series 1 × 230 V, 50/60 Hz

Pump Curve

WHMXL 32-80F/220 AUTO

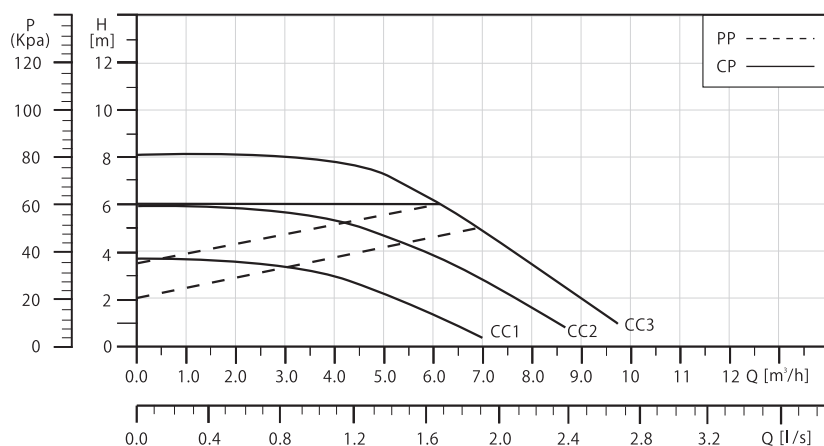

EEI ≤ 0.23

Mode	Max. head
CP	6m
PP1	5m
PP2	6m
CC1	4m
CC2	6m
CC3	8.2m

Electrical data, 1 x 230 V, 50 Hz, 5000 rpm

Speed	P ₁ [W]	I _{1/1} [A]
Min	22	0.29
Max	250	2.50

WHMXL 40-80F/250 AUTO

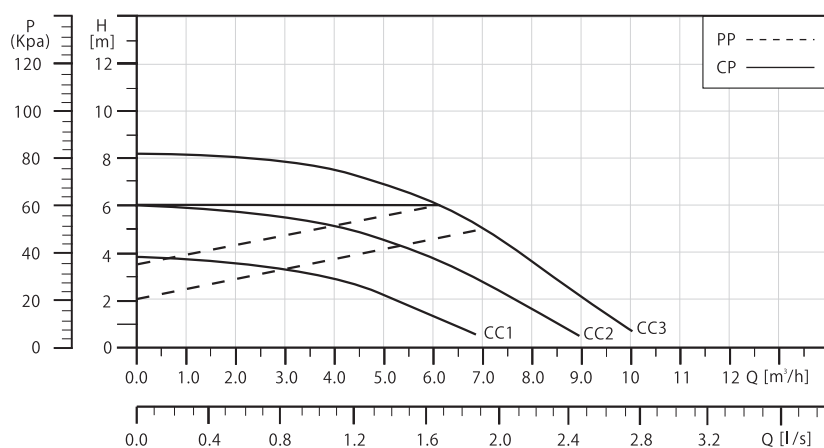

EEI ≤ 0.23

Mode	Max. head
CP	6m
PP1	5m
PP2	6m
CC1	4m
CC2	6m
CC3	8.2m

Electrical data, 1 x 230 V, 50 Hz, 5000 rpm

Speed	P ₁ [W]	I _{1/1} [A]
Min	22	0.29
Max	250	2.50

WHMXL AUTO series 1 × 230 V, 50/60 Hz

Pump Curve

WHMXL 32-100F/220 AUTO

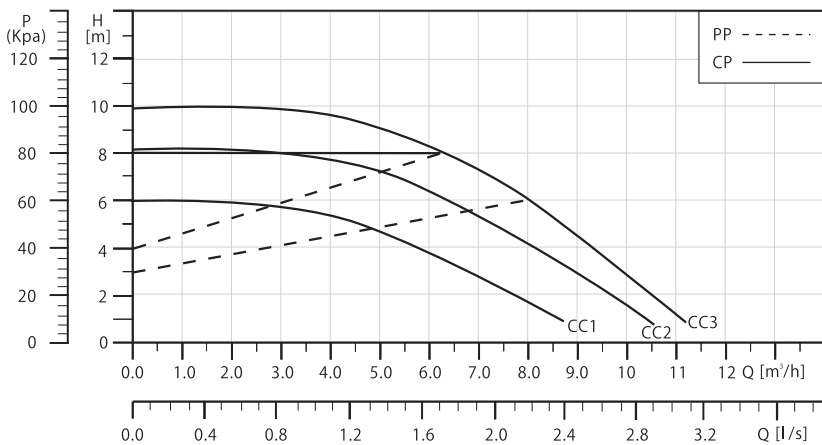

EEI ≤ 0.23

Mode	Max. head
CP	8m
PP1	6m
PP2	8m
CC1	6m
CC2	8m
CC3	9.8m

Electrical data, 1 x 230 V, 50 Hz, 5000 rpm

Speed	P ₁ [W]	I _{1/1} [A]
Min	27	0.35
Max	350	3.00

WHMXL 40-100F/250 AUTO

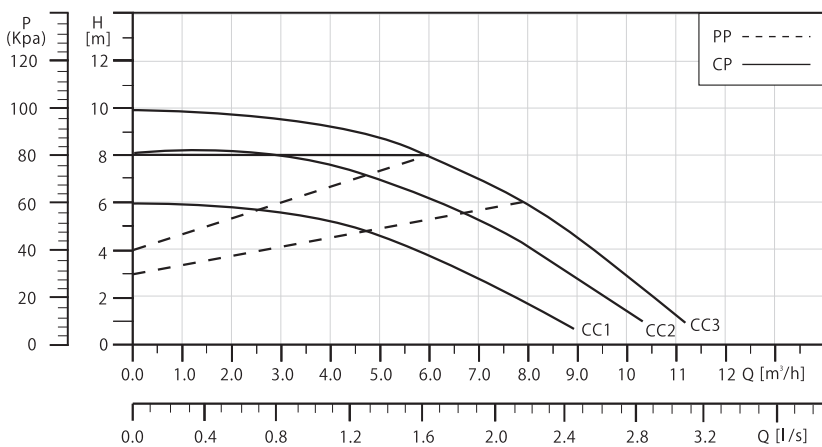

EEI ≤ 0.23

Mode	Max. head
CP	8m
PP1	6m
PP2	8m
CC1	6m
CC2	8m
CC3	9.8m

Electrical data, 1 x 230 V, 50 Hz, 5000 rpm

Speed	P ₁ [W]	I _{1/1} [A]
Min	27	0.35
Max	350	3.00

WHMXL AUTO series 1 × 230 V, 50/60 Hz

Pump Curve

WHMXL 32-120F/220 AUTO

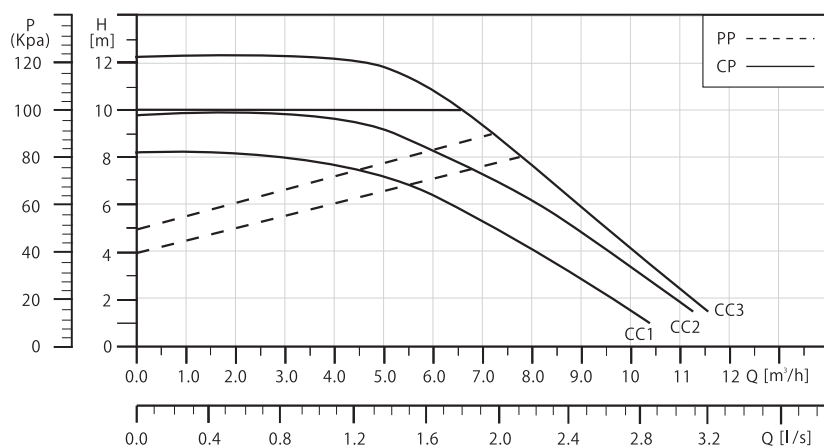

EEI ≤ 0.23

Mode	Max. head
CP	10m
PP1	8m
PP2	9m
CC1	8m
CC2	10m
CC3	12.1m

Electrical data, 1 x 230 V, 50 Hz, 5000 rpm

Speed	P ₁ [W]	I _{1/1} [A]
Min	27	0.35
Max	400	3.50

WHMXL 40-120F/250 AUTO

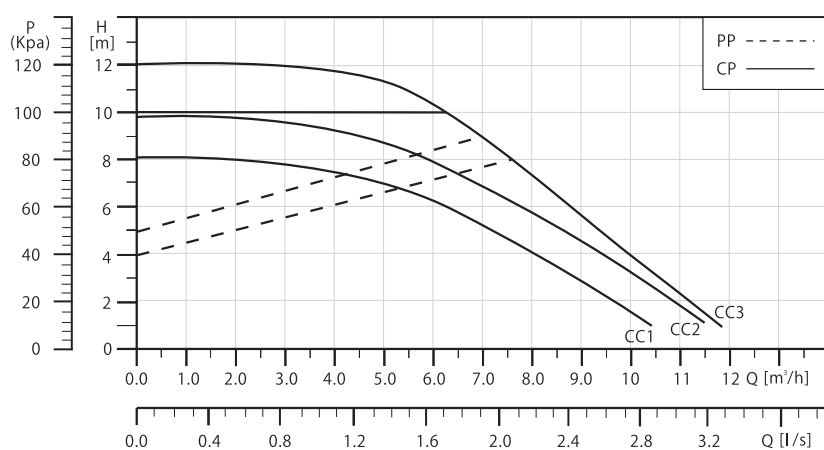

EEI ≤ 0.23

Mode	Max. head
CP	10m
PP1	8m
PP2	9m
CC1	8m
CC2	10m
CC3	12.1m

Electrical data, 1 x 230 V, 50 Hz, 5000 rpm

Speed	P ₁ [W]	I _{1/1} [A]
Min	27	0.35
Max	400	3.50